

VST Series™

Two-Stage Variable Speed
Rotary Screw Compressors



Experience Proven Results™

Smarter Solutions

COMPRESSED AIR IS AN EXPENSIVE UTILITY, BUT A NECESSARY UTILITY

In many manufacturing and commercial facilities, compressed air is often referred to as the fourth utility. Compressed air is convenient, versatile, and expensive. It is estimated that in a typical compressed air system over a 5 year period, 86 percent of the total cost is for energy consumed, 8 percent for capital, and 6 percent for maintenance. With energy costs rising to unprecedented levels, energy efficiency in a compressor package is of major importance when evaluating your compressed air system.

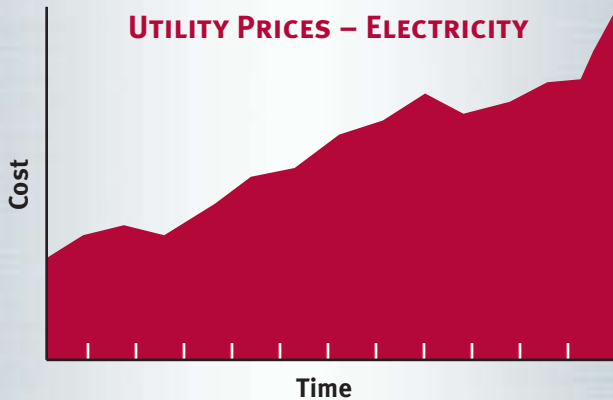

THE SUPPLY SIDE IS NOT EASILY MATCHED TO THE DEMAND SIDE

Your compressed air system has a huge impact on your plant's productivity and profitability. System design and compressor choices are important decisions with long lasting implications for your business. The wrong air system or components is costly—in the form of excess energy consumption, elevated repair and maintenance costs, downtime, poor compressed air quality, unacceptable noise levels and more. You should consider the impact your selection decision will have on the issues.

THE COMPLEX NEED— EVERY AIR SYSTEM IS DIFFERENT

COST OF COMPRESSED AIR OVER 5 YEARS

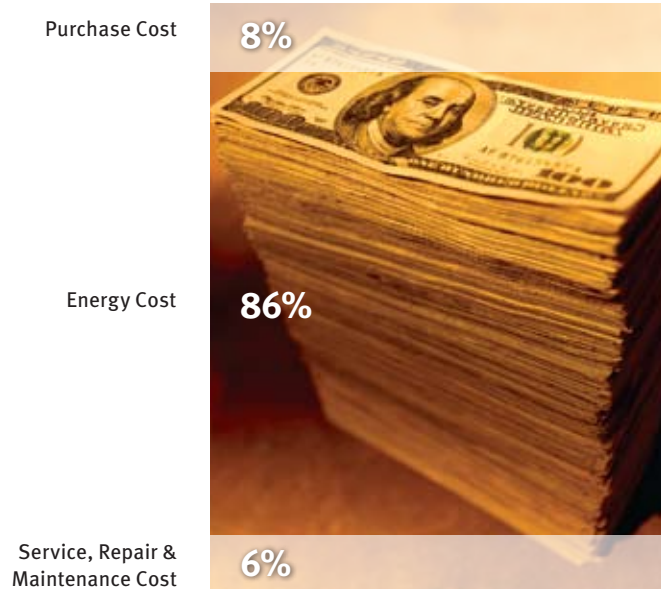

GD TWO-STAGE VARIABLE SPEED COMPRESSORS DO BOTH – THE SMARTER SOLUTION

Two-stage compression is 8–12% more efficient than single stage compression. Gardner Denver's new two-stage VST Series is a more efficient air compressor than other single and two-stage compressors on the market today. The VST Series compressor matches the compressor output (Supply Side) to the system requirements (Demand Side) at the required target pressure. The Gardner Denver VST out-performs other base load and other variable speed compressors. We provide the lowest energy cost and the widest operating range of any other compressor. With the variability found in most plant air systems and the ever-escalating cost of energy today, our VST product is the smarter solution. The VST offers a reliable and stable air supply at the lowest energy cost.

THE SMARTER SOLUTION— VST SERIES VARIABLE SPEED COMPRESSORS

THE GARDNER DENVER VST SERIES DELIVERS IT ALL

The VST Series design started from a “clean sheet of paper.” This approach is critical in making a variable speed compressor that delivers optimal performance over the widest operating range. For maximum reliability, key features must be a part of the design foundation.

GREAT EFFICIENCY AT FULL LOAD

The VST Series compressor performs at a specific power level (kW/100 CFM) that is equal to, and in most cases better than, non-drive, two-stage competitive packages.

Technology Leads The Way

Our design team utilized the latest technologies in developing the VST Series with the critical product benefits you require. These technologies include:

- **Computational Fluid Dynamics (CFD)** minimizes pressure drop from the air inlet all the way to the air discharge of the compressor package. This technology maximizes efficiency and minimizes your electrical cost of operation.
- **Finite Element Analysis (FEA)** assures that the strength and rigidity of a component is completely understood. If a weakness is identified, design changes are made before the product is produced.
- **Solid Modeling** during the design phase allows these technologies to be applied successfully. In addition, product quality and serviceability are greatly enhanced when viewed and analyzed from a solid model.
- **Thermography** is utilized to maximize heat transfer and ensure that cool, clean compressed air is delivered to the plant.

These technologies are combined with completely new air end designs that optimize efficiency across a broad operating range to minimize the cost of compressed air in your facility. A Smarter Solution designed to meet your needs!



HUGE SAVINGS AT PART LOAD

The VST Series provides tremendous power savings at part load points that save you thousands of dollars in energy costs each year. This compressor matches the supply of compressed air at the specified target pressure to your system’s specific demand while minimizing the power required to compress the air. Typical compressors either modulate the inlet valve and/or vary the displacement of the first stage to control the capacity of the package. These methods do not offer the power savings of a variable speed control matched to the most efficient compressors nor are they able to achieve the wide operating range of the VST Series products.

THE BENEFIT: EFFICIENT, RELIABLE, FLEXIBLE... UNMISTAKABLE

The VST Series is a complete and revolutionary compressor package that is a Smarter Solution to your Complex Needs. The efficiency limitations of single-stage and two-stage compressors have been eliminated to establish a new standard in performance. The flexibility of the Gardner Denver VST Series exceeds any other compressor on the market today. This means stable pressure in the plant and maximum productivity at the lowest possible electrical cost. Finally, the VST Series is so reliable it is backed by the most comprehensive warranty in the industry.

Efficiency

Delivering the Lowest Possible Electrical Cost

EVALUATE EFFICIENCY— FULL LOAD, PART LOAD, NO LOAD

Upper Range – Part Load Efficiency Gains Importance

At full load (blue area in graph at right), the VST Series compressor performance is equal to or better than other single-stage and two-stage compressors. As air demand decreases, the VST compressor becomes more energy efficient under part load conditions while other modulating units continue to consume virtually the same amount of energy to compress smaller amounts of air.

Middle Range – VST Takes Charge

In the middle range (yellow area), the VST Series compressor offers significant energy savings

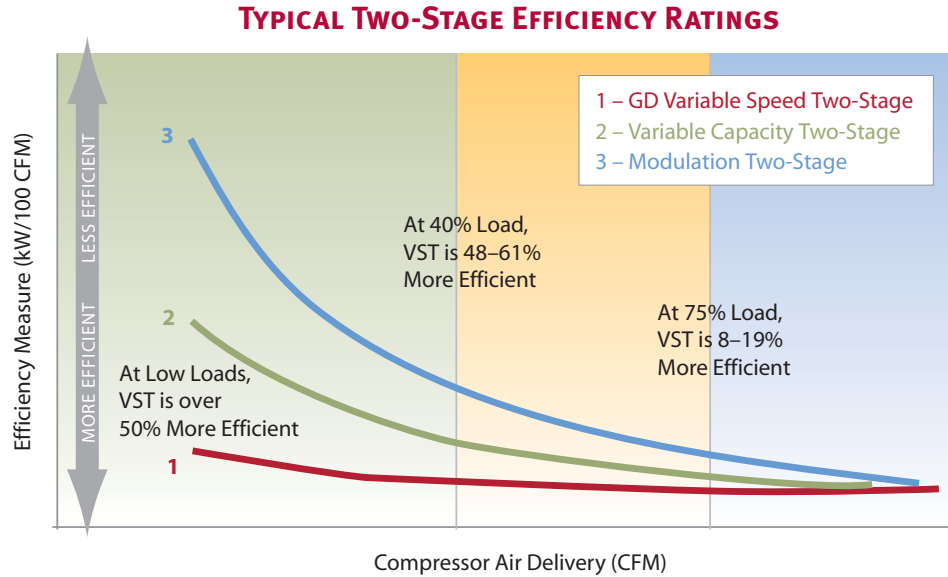

compared to the other compressor types. The VST compressor offers up to 61% better energy efficiency than other compressor manufacturers, and the advantage increases as flow demand decreases.

Lower Range – VST is Far Superior

In the lower range (green

shading), the VST compressor energy savings becomes even greater. The VST compressor can efficiently handle the varying demands of today’s air systems over multiple shift operations, saving thousands of dollars in energy cost every year, and resulting in the quickest possible return on investment.

THE VST SERIES PROVIDES MAXIMUM EFFICIENCY – FULL LOAD, PART LOAD, NO LOAD

Typical competitive variable speed single-stage and two-stage compressors are not designed to maximize performance. Most manufacturers simply adapt their current products to a variable speed drive and motor. Gardner Denver’s objective is to design the compressor, drive and motor to compliment one another resulting in the best possible energy savings over the entire operating range of the compressor. The VST Series products are specifically designed to meet this objective.

DESIGNED TO BE ENERGY EFFICIENT — NOT AN ADD-ON

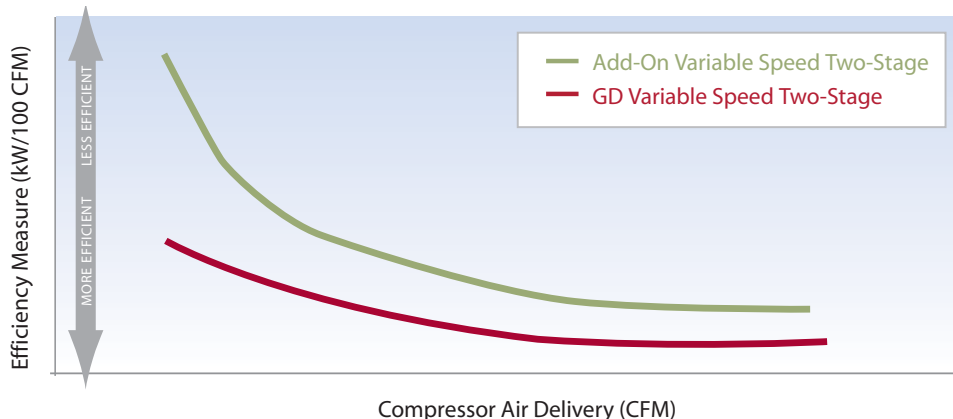

TO MAXIMIZE EFFICIENCY, THE VST SERIES ELIMINATES EVERY POSSIBLE kW



Newly Designed airends perform efficiently at all speeds

Unlimited Start/Stop Operation

When air is not needed, the VST Series compressors stop running and do not vent to atmosphere. We do not see the need to waste the compressed air in the reservoir. The “soft” starting capability of the AirSmart controller allows the motor to start against a pressurized system at any time and will do so as often as required by the system. Our attention to this energy saving detail saves you energy costs.

Airends Optimized for Variable Speed Operation

Gardner Denver invested the capital to develop new airends with new rotor profiles for the specific purpose of maximizing energy efficiency in two-stage variable speed compressors. We invested in variable speed technology rather than the conventional gear driven airends. We see this as the future of rotary screw compressors. This technology allows us to synchronize the speeds and performance of the first and second stage airends, to optimize the performance and energy efficiency throughout the operating range of the package.

Designed for Minimum Pressure Drop

For every 2 psig of pressure drop through a compressor package an additional 1% of power is consumed. Gardner Denver analyzed every facet of the compressed air stream to eliminate or minimize pressure drop. CFD analysis allowed us to model the airflow through the system and eliminate any restrictions. Our attention to detail saves you energy costs.

More Models to Choose From

We offer the widest range of two-stage models of any manufacturer in the industry. Our model range begins at 55 kW (75 horsepower) and expands to 260 kW (350 horsepower). This results in the best possible match of our two-stage compressors to your needs and the best value for your application. These compressors will turn down to 20% of their rated capacity. This allows you the flexibility to meet the diverse variability of your plant’s requirements while preserving the best possible energy efficiency.

Flexibility to Surpass Your Goals



The VST Series saves time, saves money, maximizes plant productivity—It's like having several efficient compressors in one. Smart!



CAPABILITY TO MEET VARYING COMPRESSED AIR DEMANDS

- Shift-to-shift, weekday-to-weekend, or season-to-season... we offer the widest turndown range in the industry. In other words, we have a greater capability to handle variable air demand requirements.
- Selectable pressure from 100–175 psig at the touch of a button—no need for a new compressor when your pressure requirements change.
- Quick response to pressure changes that maintains target pressure within +/- 1 psi. This provides stable plant pressure resulting in higher productivity.
- Full line of compressors to match your compressed air requirements from 55 to 260 kW. With more models, we can perfectly match your needs.
- System storage requirements are minimal. The VST Series is capable of maintaining a +/- 1 psi pressure bandwidth with as little as ½ gallon of storage per cfm output. Other manufacturers require a minimum of 2 gallons of storage per cfm output.
- The VST compressor is the most efficient compressor you will purchase. The VST is comprised of two independent compressors and drive systems. The first stage is designed for greater volume at lower pressure while the second stage is designed for the most efficient compression ratio. The AirSmart™ controller monitors your system demand in real time and controls the speed of both stages of compression, exactly matching the required demand while using no more energy than is needed to meet the demand.

Reliability

To Maximize Uptime

DESIGNED FOR RELIABILITY

We used a “clean sheet of paper” design approach, with all components carefully selected and tested for their specific performance and purpose.

The VST Series design incorporates *stepped-injection technology*. This allows the AirSmart™ controller to maintain the discharge temperature of the compressor above the dew point to prevent condensate from forming in the lubricant. **Smart!**

Gardner Denver designed the first and second stage compressors as independent compressors and drives. This choice allows the AirSmart™ controller to synchronize the second stage compressor speed to the exact needs of the first stage—optimizing the input power of the package. The result is the most efficient supply of compressed air to your system demand at the lowest possible energy cost. Reliability and efficiency have been designed into each component in this system to assure you maximum performance and dependability.

A Warranty Like No Other

In simple terms, VST Series compressors have a **best-in-class** warranty. A five-year warranty is available for the drive motor, airend, variable frequency drive, controller and more. With regular lubricant sampling and use of OEM parts & lubricant you are guaranteed to have a compressor that exceeds your reliability expectations.

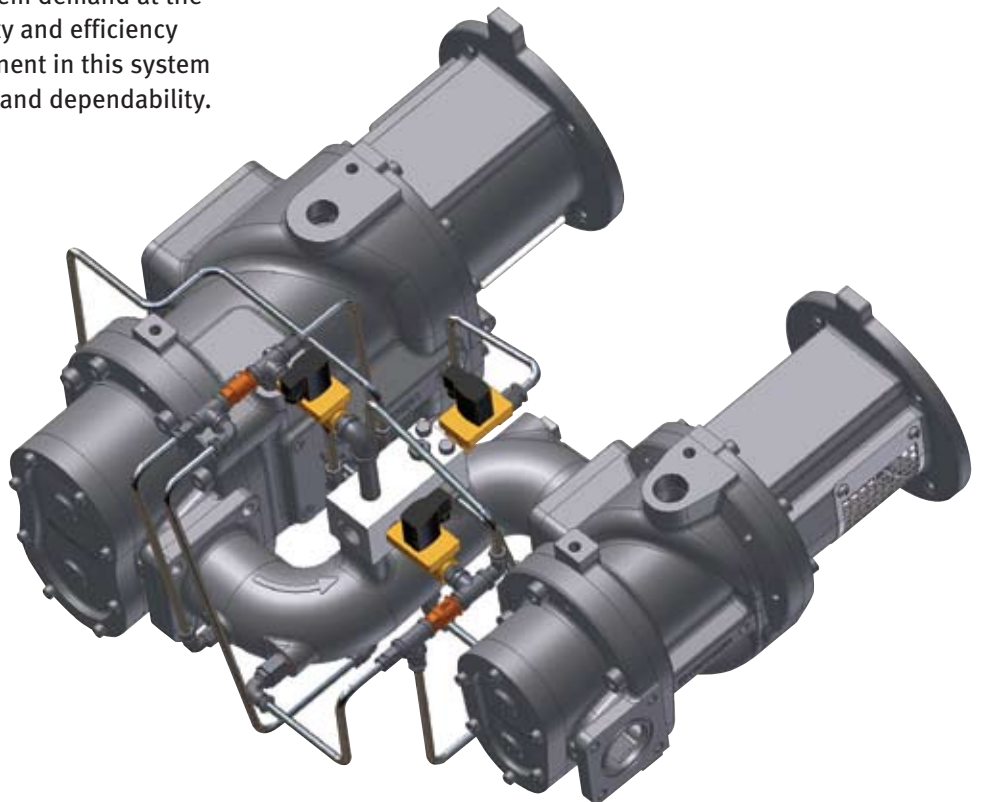

The AirSmart™ Controller

Orchestrating Your Compressed Air System

Simplicity

The AirSmart Controller was designed to make the operators' interface with the variable speed drive transparent. You don't need to be an expert on variable speed drives to operate our compressor. The controller takes care of the details.

The controller automatically adjusts the compressor's performance to meet your changing air system demands—saving you energy dollars.

Changing the discharge pressure is as easy as pressing a button. No longer is there a need for a new machine when your pressure demands change.

Communication & Sequencing

The optional communication module allows the VST Series units to talk to each other and other Gardner Denver compressors to optimize system efficiency. This isn't just an hour balancing, on/off sequencing scheme. Our controller allows the system to truly optimize efficiency because it knows the capabilities of other machines and orchestrates their operation.

The communication module also allows remote monitoring of the VST units.

Advanced Display

The controller has a four line display with menus and tactile buttons for easy navigation. Two lines display operating information such as pressure, temperature, operating hours, etc., while the other two lines display advisory messages, shutdown messages, recommended part numbers, and service contact information.



100 PSI
326 HRS
ENERGY COST 3.78 \$/KWH

88°F
AUTOMATIC
LOADED 75%

SHUTDOWN
SERVICE
AUTOMATIC
POWER

ENTER

STOP/RESET

RUN

Energy Efficient at All Load Levels

COMPRESSOR ENERGY COST ESTIMATOR

Nominal kW	Operating Cost per Year (5000 hours) at Cost per kWh (\$)				
	\$.04	\$.06	\$.08	\$.10	\$.12
55	11,000	16,500	22,000	27,500	33,000
75	15,000	22,500	30,000	37,500	45,000
90	18,000	27,000	36,000	45,000	54,000
110	22,000	33,000	44,000	55,000	66,000
150	30,000	45,000	60,000	75,000	90,000
180	36,000	54,000	72,000	90,000	108,000
220	43,600	65,400	87,200	109,000	130,800
260	52,000	78,000	104,000	130,000	156,000

Note: Hours of operation based on two 8-hour shifts, 6 days per week.
Calculations based on nominal kW.

esaver
ENERGY COST CALCULATOR

The single largest “cost” item, during the life of a compressor is the cost of the electricity required to run the compressor. With *esaver*, the Gardner Denver Rotary Screw Energy Cost Calculator, no matter what load demand, the cost of the electricity used by a compressor can be calculated. Ask your local Gardner Denver Authorized Distributor to demonstrate this unique cost-saving tool.



Making Your Job Easier

ENVIRONMENT

Serviceable Yet Compact Footprint

Our entire VST line was designed with a compact footprint for space-saving, money-saving installation.

Super Low Sound

All VST models are enclosed for quiet, environmentally-friendly, and employee-friendly operation.



Gardner Denver, an **ENERGY STAR PARTNER**, is committed to developing products and introducing technologies that help conserve energy and protect the environment.

SERVICEABILITY & PRODUCT SUPPORT

Serviceability

Great attention was given during the design of the VST line to ensure that our compressors are easy to service and maintain.

Support Network

Gardner Denver has a network of trained service providers available whenever needed to keep your compressors in top form. We are committed to stocking components to support your compressed air system needs.

Aftermarket Products

Gardner Denver carries a full line of aftermarket products to meet your full system needs.

Designed to deliver
SMARTER SOLUTIONS
 for your complex needs!



<http://www.esp2020.com>

ESP 20/20

Single Compressor Remote Monitoring

ESP 20/20 is a wireless remote monitoring solution that upgrades the air compressor to an intelligent asset providing system performance and advisory notification. Interfacing directly to Gardner Denver or third party compressors via discrete inputs and outputs, any compressor asset can be transformed to provide critical operational information through a single web-based application.

WIRELESS:

Installation Has Never Been Easier

One of the unique features of ESP 20/20 remote monitoring is wireless access to the compressor. This feature is only offered by Gardner Denver's ESP 20/20 and provides significant advantages over IP/Network or RS232/Serial based systems.

- Eliminates time and expense of running CAT5 or other types of cabling to the compressor.
- Eliminates IP configuration and Network setup.
- No need to access IT experts for installation.
- Remote monitoring channel is isolated from your IP network for excellent security.
- Flexibility in where a compressor can be located.
- Ease of relocating a compressor, if needed, without having to re-route wires.



Avoid IT wiring headaches with a wireless solution

ENTERPRISE/WEB BASED SOLUTION:

Anytime, Anywhere Access

ESP 20/20 is an enterprise web-based solution, a Gardner Denver exclusive feature, which provides substantial advantages over peer to peer solutions offered in most competitive products.

- Allows multiple compressor assets, at single or multiple locations, to be viewed from single web-based interface.
- No application software needed to view and monitor compressor assets.
- Easy access from any computer anywhere with access to the internet.
- Enterprise password protection allows passwords to be assigned to specific personnel at appropriate levels.
- Alert preferences for personnel are assignable to meet individual needs.
- Automatic notifications of advisories, alarms, or scheduled maintenance via email, text, page, or voice to match today's mobile technology and work environment.

GD XTRA
10 Year Protection

ESP 20/20 qualifies the compressor for **GD XTRA**, Gardner Denver's extended warranty program on airends, delivering the tools to ensure the compressor is operating at peak performance with the peace of mind that the compressor is protected.

Let Gardner Denver Take Control of Your System

To ensure total system reliability, Gardner Denver provides a broad range of dryers, filters, oil/water separators, drains, cleaning fluids, and aftercoolers. ONE-STOP shopping from Gardner Denver assures that all components of the system are designed to work together and are backed by customer support today and for years to come.



FIL Series High Efficiency Filters

A full range of filters 20–21,250 cfm; coalescing, particulate, and activated carbon for the removal of water, oil, and particulates from compressed air.



DS2 Series Evacuator Drain Valves

A full family of zero air loss, energy efficient demand drains. Ruggedly designed to effectively and reliably prevent moisture damage to dryers, air tools, gauges, and other critical components.



RNC Series Refrigerated Dryers

A full line of high quality refrigerated dryers with features and benefits unmatched by the competition. Designed to produce dew points as low as 38°F in compressed air.



DGH Series Desiccant Dryers

A complete line of desiccant dryers for the removal of water vapor in compressed air to dew points as low as -100°F.

Gardner Denver®

www.GardnerDenverProducts.com maggie@gardnerdenver.com

Gardner Denver, Inc. 1800 Gardner Expressway, Quincy, IL 62305
Telephone: (800) 682-9868 FAX: (217) 224-7814

©2009 Gardner Denver, Inc. Printed in U.S.A. GS-VST-FAM 2nd Ed. 10/09



Member



Please recycle after use.