

# Electra-Saver®

Variable Displacement Compressor



Experience Proven Results™

## Energy Efficiency

**STANDARD**  
**5 year Motor Warranty**

### Efficiency

Efficiency is defined as the ratio of *useful output* to *total input* for any productive activity. Increasing efficiency is simply accomplishing more with less. Less time, less energy, less waste. Bottom line, LESS COST.

Consider a compressed air system. Compressed air is often referred to as the “fourth” or “phantom” utility because it is relied upon to keep dependent processes operating at maximum output. As long as operating pressures are maintained by an adequate supply of compressed air, not much thought is given to where the air is coming from and how much it costs. All the while, the compressor continues to run in the background as a silent partner.



50–500 HP 60 HZ  
100–500 HP 50 HZ

# The Cost of Compressed Air

## Ever consider the cost of compressed air?

The initial capital investment and periodic maintenance requirements are critical factors in the decision to purchase a packaged air compressor. These are certainly important issues, but also consider the energy costs associated with the “phantom” utility. The energy costs can easily exceed the initial capital expenditure within the first year of operation. Over the life of the compressor package, the energy costs dominate the total cost of providing compressed air.

## Compressed Air is Not Free

Choose the nominal size of an air compressor and cost of electricity to estimate annual energy costs.

## COST OF COMPRESSED AIR OVER 5 YEARS

Purchase Cost

8%

Energy Cost

86%

Service, Repair & Maintenance Cost

6%

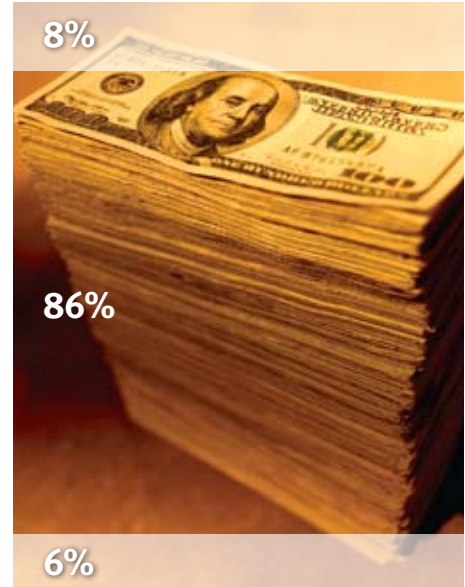

**WOULDN'T IT MAKE SENSE** to design a compressor that started saving money the minute you turned it on?

Nominal HP	Operating Cost per Year (5000 hours) at Cost per kWh (\$)				
	.04	.06	.08	.10	.12
10	\$ 1,834	\$ 2,751	\$ 3,667	\$ 4,584	\$ 5,501
15	2,705	4,058	5,411	6,763	8,116
25	4,474	6,712	8,949	11,186	13,423
30	5,329	7,993	10,657	13,321	15,986
50	8,824	13,235	17,647	22,059	26,471
75	13,081	19,621	26,162	32,702	39,242
100	17,441	26,162	34,822	43,603	52,323
150	25,914	38,871	51,827	64,784	77,741
200	34,552	51,827	69,103	86,379	103,655
300	51,181	76,771	102,362	127,952	153,543
400	68,241	102,362	136,482	170,603	204,723
500	85,036	127,554	170,073	212,591	255,109

Note: Hours of operation based on two 8-hour shifts, six days a week.  
BHP based on nominal horsepower plus 10%.

## Large Direct-Driven, Slow Turning Screws = Efficiency

### THE ELECTRA-SAVER®

Gardner Denver® proudly introduced the first oil-flooded rotary screw compressor to the domestic market over 40 years ago. The large-diameter, slow-turning screw air end packaged with heavy-duty industrial grade components soon became a cornerstone for serious compressed air users and a template for competitive design philosophies. Throughout the years, Gardner Denver has remained committed to providing equipment that offers superior service and economical operation over the life of the machine.

### BIGGER IS BETTER - GREATER ENERGY EFFICIENCY

The only reason to make a compressor air end small and turn it at high speeds is to minimize cost. If maximum energy efficiency is desired, the air end should be large and run at slow speeds.

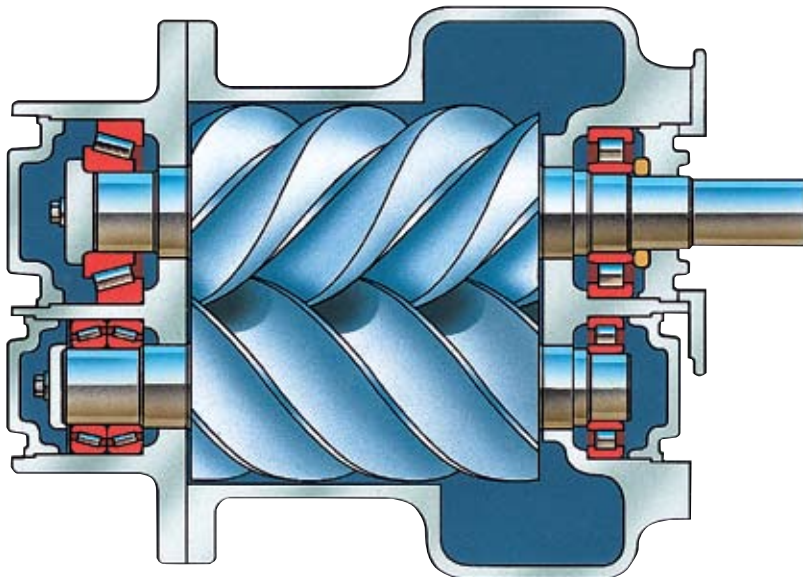
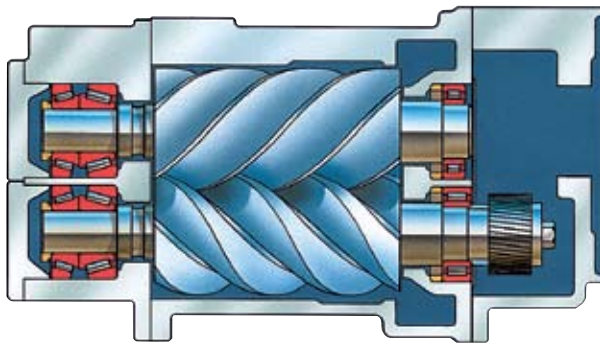

Up to 41% larger, Gardner Denver air ends operate more slowly and efficiently than smaller, gear-driven types.

### Reduced Air Blow Back

At high speeds, more air leaks back across the rotors during the compression process. Simply put, the faster the rotors turn, the harder it is for the rotors to trap and hold the air as it is compressed. Superior machining of the rotors cannot offset this advantage since large rotors can be machined to the same tolerances as small ones. To maximize efficiency, minimize speed!

### Reduced Lubricant Drag

In an air end, the rotors have to “cut through” heat-reducing lubricant. And the fact is, less drag on the rotors occurs at slower speeds. In addition, lubricant is injected into the compression chamber at precise locations to minimize viscous drag and maximize the cooling effect. *Every* area of the compressor is designed to maximize energy efficiency.

### SMALLER LEAKAGE AREAS

Though this sounds technical, it is quite simple. The areas between the rotors and the rotor housing are leakage areas where air can escape and reduce efficiency. As rotor size increases, these leakage areas become a smaller percentage of air output.

### LARGE, DURABLE, SUPER-SIZED BEARINGS

Of course, a larger rotor weighs more than a small rotor, so you would expect it to have a larger bearing. The key is that large rotors provide more than ample area to “super-size” the bearings if desired. That’s why for years, Gardner Denver has been one of the few manufacturers to put bearing life numbers in our literature. When you super-size this critical component, you’re proud to say you design for a minimum  $L_{10}$  life of 100,000 hours.

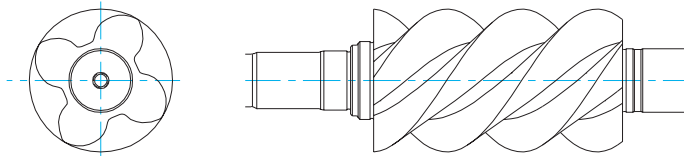

### ROTOR SIZE COMPARISON

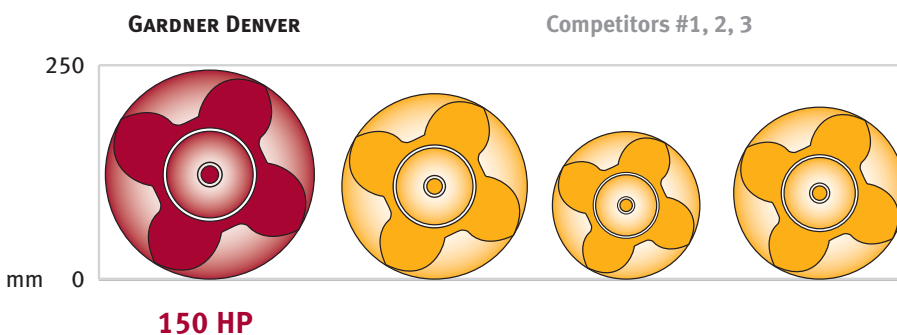
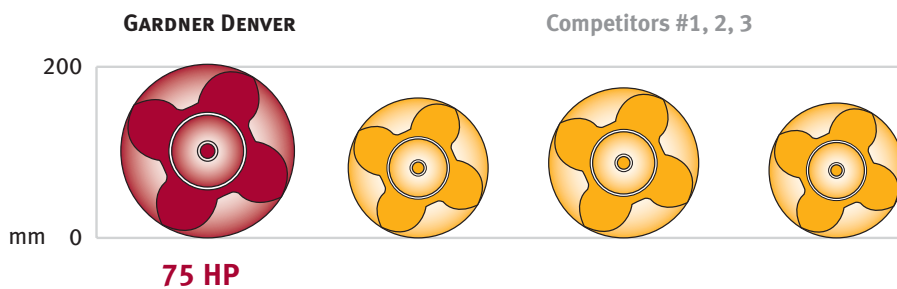

Greater operating efficiency and long term durability are the results of designing large diameter rotors to operate at low rpm.

# The GD Turnvalve™

## Variable Displacement Technology



### Basic Operating Principle

Air is drawn in through the fully opened inlet by the “unmeshing” action of the rotating screws.

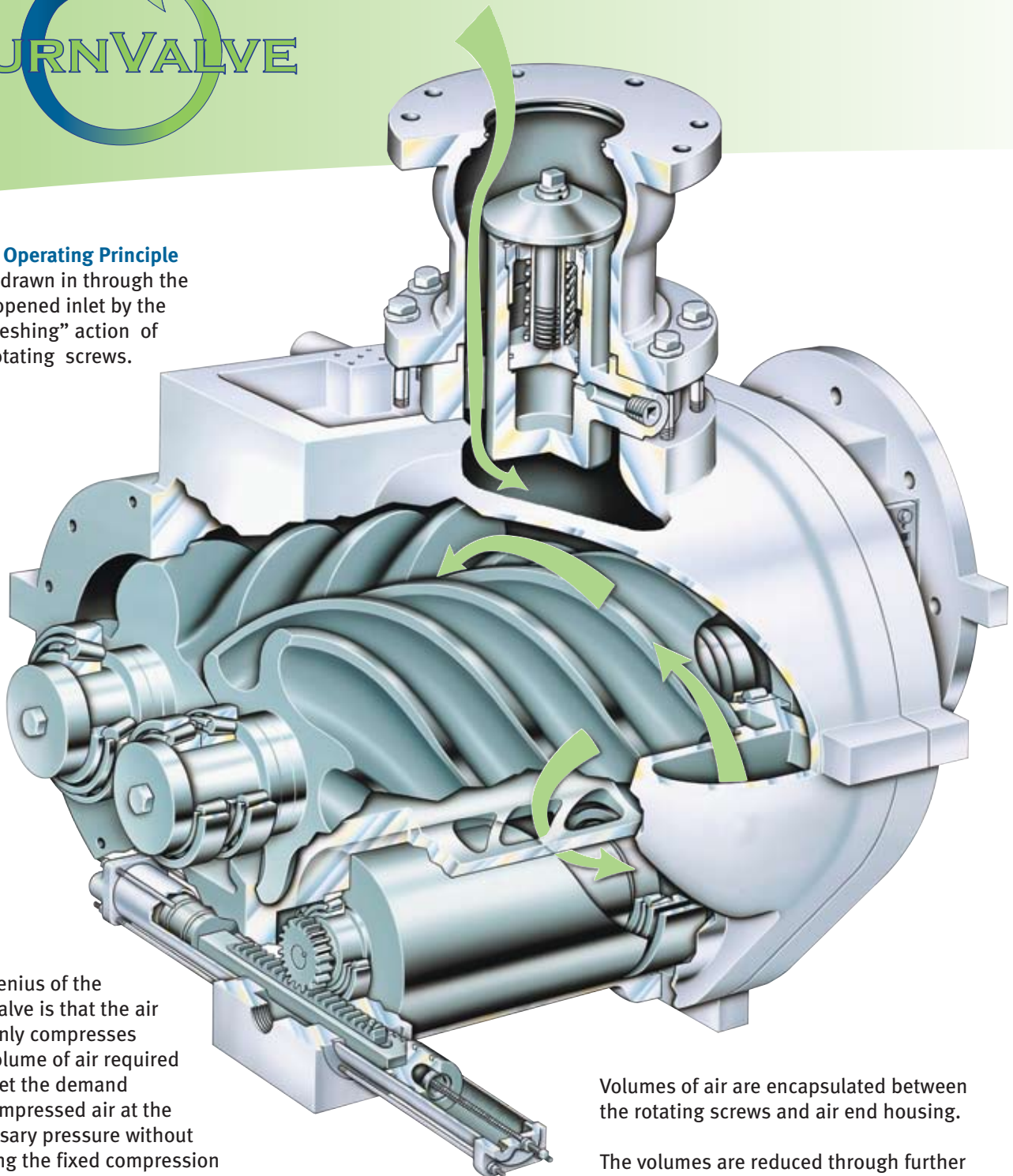

The genius of the TurnValve is that the air end only compresses the volume of air required to meet the demand for compressed air at the necessary pressure without altering the fixed compression ratio of the air end.

Volumes of air are encapsulated between the rotating screws and air end housing.

The volumes are reduced through further rotation of the screws to a fixed compression ratio and discharged out of the air end at operating pressure.

The diverse and dynamic nature of compressed air systems has a direct impact on how a machine operates after it has been installed. Even with careful planning and use of such strategies as point of use storage, most systems experience air demand variation that yields a supply-side capacity which is often greater than the compressed air demand for significant periods of time. As a result, compressors operate below their full-load rated capacity at what is

most commonly referred to as “partial load”. The horsepower consumed at partial load operation can be significant. For example, a throttled-inlet screw compressor operating at 65% flow capacity still requires up to 91% of its full load horsepower!

Gardner Denver recognized this fact and developed a variable displacement technology designed to match compressor output to compressed air demand. The patented TurnValve was

introduced over 25 years ago to maximize compressor efficiency by compressing only the volume of air required without affecting the built-in compression ratio at partial load conditions. The TurnValve displaced inlet throttling technology as the most efficient means of compressor capacity control and **eliminated** wide pressure fluctuations and massive storage requirements professed by alternative capacity control methodologies.



The cylindrical TurnValve has a helix-shaped relief on its outside diameter which mates to a precisely machined bore within the body of the air end housing. The TurnValve is supported axially by oversized tapered roller bearings to permit rotation through a hydraulically operated rack and pinion arrangement.



Openings or “windows” conjoin the compression chamber of the air end with the TurnValve bore where the circumference is sealed by tight clearances and lubricant to prevent air leakage during operation.



When full capacity is required, the TurnValve is positioned such that the windows are “closed,” resulting in maximum volume output of the air end.

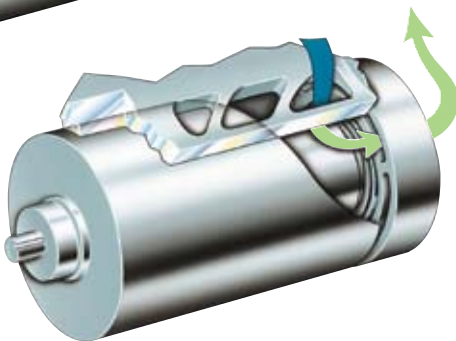

Upon detection of decreasing system air demand (rising pressure), the TurnValve is rotated into a position where the helix relief progressively opens the succession of windows until system air pressure has stabilized.

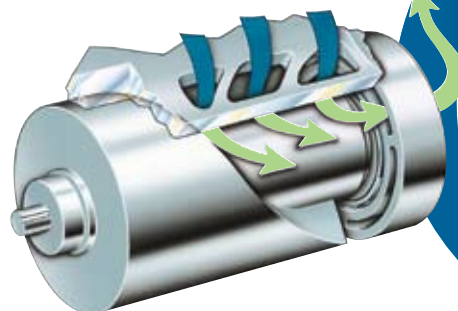

Trapped volumes of air are allowed to circulate back to the inlet without being compressed, resulting in only the required amount of air being compressed to meet system demands. The effective length of the rotor is shortened resulting in variable displacement operation allowing power use to drop, thus saving energy.

# Part Load Energy Efficiency — EE101

## The Truth About Throttled Inlets

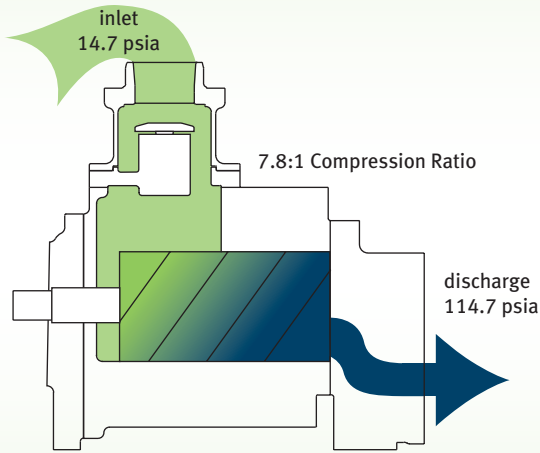

**Figure 1** Throttled Inlet Control, 100% Capacity, 100 psig Discharge

Both rotary screw compressors above are operating at 100% capacity at 100 psig discharge pressure. At 100% capacity, both have a compression ratio of 7.8:1 (114.7 psia/14.7 psia). As the compressed air demand decreases, the compressor responds to increasing system

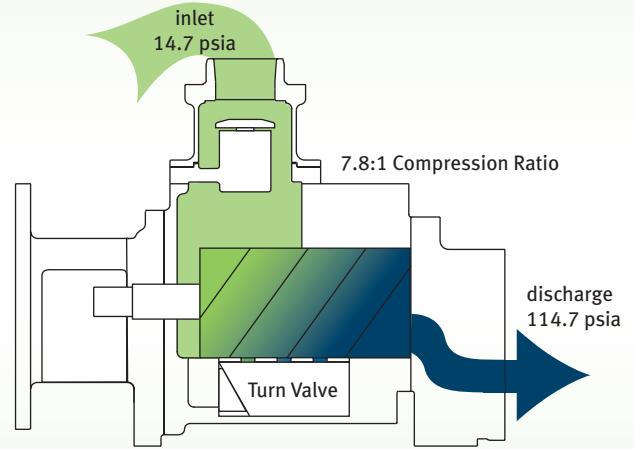

**Figure 2** Turn Valve Control, 100% Capacity, 100 psig Discharge

pressure by closing the inlet in the case of the throttled inlet type compressor, or by effectively “shortening the rotor length” as with the TurnValve equipped compressor.

## Load-No Load Operation and Storage Myths Revealed

The Ideal Part Load Capacity Curve is widely misapplied to rotary screw compressor operation. The origin for this part load calculation goes back to a method used for calculating part load energy of reciprocating compressors fitted with suction valve lifting devices. Here, the transition from full load power requirements to minimum unloaded power requirement is instantaneous. This is sound theory for reciprocating compressors, but not representative of rotary screw compressor operation. Factors such as compressor blow-down time, time spent in unloaded condition while system pressure drops from a maximum compressor pressure set-point to the minimum pressure reset-point and the time needed to fill the system while compressed air consumption is taking place tend to skew the Ideal Curve as shown. Compressed air storage is commonly used to buffer compressor operation to facilitate the most efficient load/no load or on/off operation of the machine.

Storage is defined as a supply of compressed air maintained at a higher pressure than required by the demand system. The greater the volume of storage, the longer the period of unloaded/blown-down operation. This increases the potential to completely turn off the compressor, reducing energy requirements. However, the opposite is true. The lesser the volume, the tendency for short cycling exists as the compressor works to maintain the required system pressure. Reduced energy requirements are diluted by frequent blowdowns (unrecoverable losses), the re-filling of the supply side with compressed air (package and storage system) and the fact that a higher pressure must be maintained for effective storage. A rule of thumb is that every 2 psig increase in pressure requires an additional 1% of compressor full load horsepower.

**The bottom line is that for load/no load or start/stop operation, the receiver must be sized such that there is 10 gallons of storage for every cubic foot of delivered air for maximum energy efficiency.**

The AutoSentry® ES+ microprocessor based compressor controller has built-in control flexibility to allow selection of Load-No Load operation for the Electra-Saver when adequate storage capacity is available.

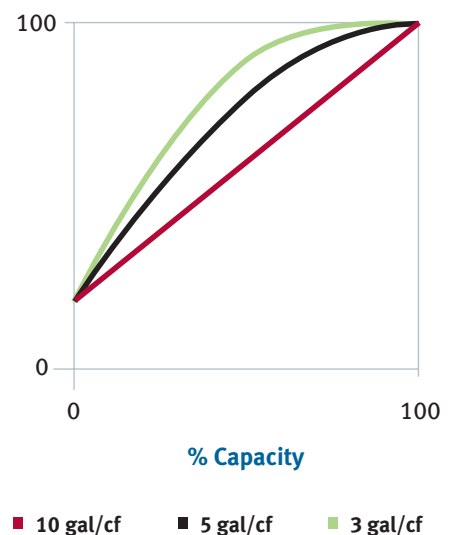

## How is the TurnValve one of the most efficient part load capacity control?

The TurnValve simply reduces the volume of air compressed to maintain a constant discharge pressure at a single compression ratio without electronic complication.

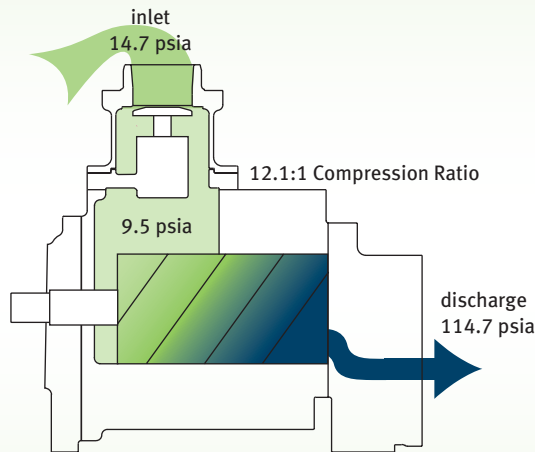

**Figure 3** Throttled Inlet Control, 65% Capacity, 100 psig Discharge

The partially closed inlet valve does reduce the flow of air to the compressor, but the restriction creates a vacuum at the inlet that also reduces the inlet pressure. At 65% capacity, the compressor now operates at a compression ratio of 12.1:1 (114.7 psia/9.5 psia) to maintain a constant 100 psig discharge pressure. Power reduction gained through the decreased flow is largely cancelled by the increase in power requirements due to the 55% increase in compression ratio. As a result, this compressor requires approximately 91% of full load capacity horsepower to produce 65% of full load capacity!

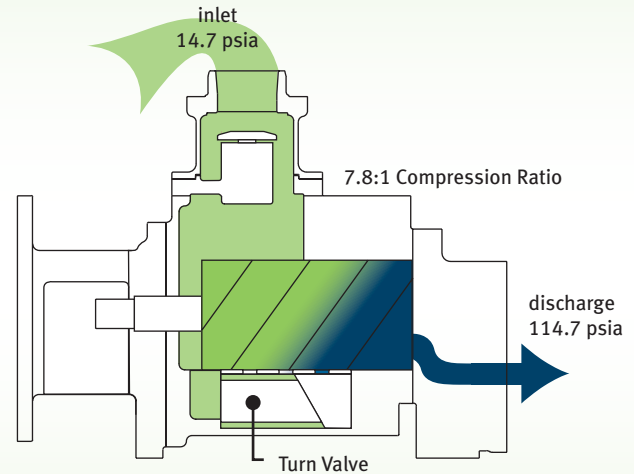

**Figure 4** TurnValve Control, 65% Capacity, 100 psig Discharge

Unlike the throttled inlet system, the TurnValve control does not restrict the inlet of the compressor. The volume of air compressed is reduced as the TurnValve progressively opens a succession of windows in the compression chamber to maintain a constant discharge pressure. Unneeded air is recirculated to the inlet **BEFORE COMPRESSION BEGINS**. As a result, the pressure at the inlet remains constant at 14.7 psia resulting in a constant compression ratio of 7.8:1. The TurnValve rotary screw compressor only requires 75% of full load power to meet a demand of 65% full load capacity. *True part load efficiency defined.*

## Infinity and Beyond

Some control methodologies adopt an abbreviated version of the TurnValve's efficiency. Staged or banked valves purport a slight efficiency advantage over the TurnValve, but only at distinct points of compressor capacity. Their part load capacity curve looks like a set of stairs, again with the greatest efficiency at four or five distinct points of compressor capacity – this is good if the compressed air demand occurs exactly at these points. Otherwise the supply exceeds the demand and throttling or load/no load operation takes over which dilutes any gains in efficiency.

The TurnValve is infinitely positionable within its operating range of 40% to 100% of compressor capacity. This means that whatever the demand, the TurnValve provides the exact amount of compressed air to maintain system pressure for maximum efficiency – no more, no less.

Straightforward design, precise operation and control flexibility make the TurnValve the most efficient part load capacity control for the vast majority of compressor applications.

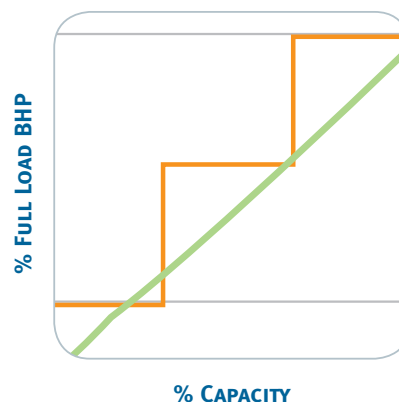

# Final Analysis

## Part Load Capacity Controls

Partial Load Capacity Power Curves

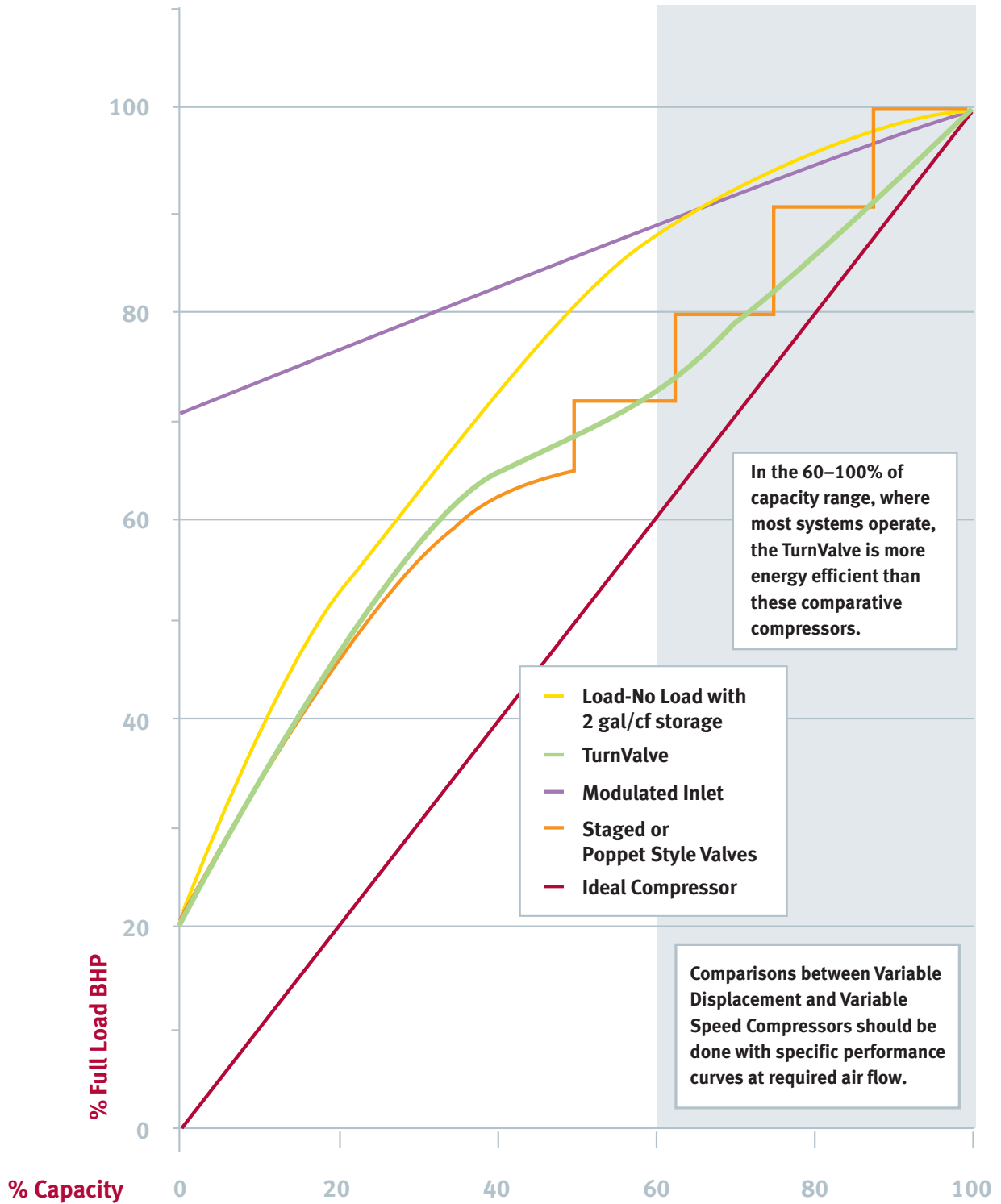

## Partial Load Energy Requirements

### AS A PERCENTAGE OF FULL LOAD BHP FOR DIFFERENT CONTROL TYPES

% OF FULL LOAD COMPRESSOR CAPACITY	APPROXIMATE PERCENT OF FULL LOAD ENERGY REQUIRED PER CAPACITY CONTROL TYPE			
	TURNVALVE		MODULATION	
	WITH BLOWDOWN	WITHOUT BLOWDOWN	WITH ON/OFF LINE (PLUS 10 GAL/CF STORAGE)	WITHOUT ON/OFF LINE
	1	2	3	4
100	100	100	100	100
90	93	93	97	97
80	85	85	92	92
70	78	78	88	88
60	72	72	84	84
50	67	67	60	80
40	64	64	52	76
30	57	57	44	72
20	50	50	36	68
10	34	45	28	64
0	20	40	20	20

### Consider the following example

By conducting an air system audit, a manufacturer has identified a compressed air usage profile for his facility:

First Shift (9 hrs/day) – 990 cfm average  
 Second Shift (9 hrs/day) – 850 cfm average  
 Third Shift (6 hrs/day) – 650 cfm average

System storage capacity – 2000 gallons or 2 gal/cf based on first shift usage.

Electricity cost - \$ 0.08/kw-hr

A 200 hp watercooled package is to be purchased from the following quoted machines with the noted performance characteristics:

- A - 993 cfm and 220 bhp @ 100 psig with a combination of modulated inlet and on line/off line controls
- B - 1010 cfm and 223 bhp @ 100 psig with poppet-style capacity control
- C - 1020 cfm and 217 bhp @ 100 psig with on line/off line control
- D - 1013 cfm and 236 bhp @ 102 psig with variable speed drive capacity control
- E - 1020 cfm and 220 bhp @ 100 psig with TurnValve capacity control

To calculate the estimated annual energy cost for compressor “A” operating under the described profile:

- Dividing the required flow by the full load capacity of the machine yields the % load under each operating condition:  $990/993 = 99.6\%$ ,  $850/993 = 85.6\%$  and  $650/993 = 65.5\%$ .
- Selecting the “Load/No-load” curve from the chart at the left, the % capacity loads from 1. correspond to % bhp values of 100%, 96% and 90% respectively.
- Multiplying the % bhp value for each load with the full load power results in 220 bhp, 211 bhp and 198 bhp for each shift of operation.
- Converting the power requirements to kW (using EPA minimum motor efficiency of 95%) and multiplying by the hours of operation at the specific load and by the cost of electricity results in the following:

$$\frac{(220 \text{ bhp} \times .746 \text{ kW/bhp}) \times 3159 \text{ hrs/yr} \times .08 \text{ \$/kW-hr}}{.95} = \$43,659/\text{yr}$$

$$\frac{(211 \text{ bhp} \times .746 \text{ kW/bhp}) \times 3159 \text{ hrs/yr} \times .08 \text{ \$/kW-hr}}{.95} = \$41,873/\text{yr}$$

$$\frac{(198 \text{ bhp} \times .746 \text{ kW/bhp}) \times 2106 \text{ hrs/yr} \times .08 \text{ \$/kW-hr}}{.95} = \$26,196/\text{yr}$$

Summing the calculated costs results in an estimated annual energy cost of \$111,728 to operate the compressor at the specified conditions.

- Repeating the process for compressors B, C, D and E using the appropriate capacity curve yields the following:

Compressor Model	Annual Energy Cost	TurnValve Savings
A	\$ 111,728	\$ 10,293
B	\$ 105,031	\$ 3,596
C	\$ 108,521	\$ 7,086
D	\$ 105,801	\$ 4,366
E – TurnValve	\$ 101,435	–

# Lowest Total Cost through Genuine GD Parts

## CONTROL THAT IS Sheer Brilliance



Maximizing the efficiency of the Electra-Saver TurnValve is a state of the art microprocessor control that is...

### SIMPLE

# S

Our first priority is to offer a controller that is user friendly. If you wish, just use the easy push buttons to turn the compressor on when you need air and off when you don't. How much additional power you use is up to you.

### HELPFUL

# H

Prior to microprocessor controllers, servicing and troubleshooting compressors were time consuming and complex. Now, the AutoSentry® microprocessor controller tells you what is needed in an easy-to-read text display. Using the Auto Sentry leaves more time to focus on the important things—production and profit.

### ENERGY

# E

### EFFICIENT

# E

With a microprocessor-controlled compressor, response time to changes in air demand is practically instantaneous. This response reduces pressure fluctuations in the plant, maximizing productivity while minimizing energy use. An energy efficient controller combined with an energy efficient compressor equals savings year after year.

### RELIABLE

# R

Gardner Denver was the first to introduce the microprocessor controls on compressors more than a decade ago. Control in this manner is far more reliable than it was with mechanical valves and switches. In addition, this technology offers the greatest degree of resistance to electrical surges in the industry.

## THE BOTTOM LINE

The Gardner Denver Electra-Saver packaged compressor equipped with the patented TurnValve variable displacement capacity control and the AutoSentry ES+ microprocessor controller yields the greatest flexibility for maximum operational efficiency because...

### Not all compressed air systems are created equal!

- All the way from 60% to 100% capacity – Electra-Saver performance is the most consistent with the “ideal” curve
- System pressure sampled in 1/16 psi increments and infinite positioning capability of the TurnValve ensure instantaneous and precise reaction to changes in compressed air system demands – energy is not wasted by over-pressurizing the system
- AutoSentry ES+ control flexibility features the option to select TurnValve or Load/No-Load operating modes – maximizing efficiency for your specific application
- The reliability of the TurnValve is a direct result of its simplicity in design – no complicated electronics or intricate valving to troubleshoot
- Tens of thousands of Electra-Savers are operating all over the world...



**PROVEN RELIABILITY,  
PROVEN SAVINGS**

## Premium Package Features



### Stainless Steel Rather than Hose

A premium compressor utilizes stainless steel control lines and seamless tube for lubricant circulation. If offered by a competitor, it can be a \$400–\$1500 adder. Why accept leaks and failures when you don't have to?

### Cool Air through Proper Cooling

Some compressors overheat or deliver hot air when the going gets tough. Electra-Saver coolers allow for operation in 110°F ambient while delivering air to within 15°F of the inlet air temperature. Big coolers, big air ends...big difference.

### TurnValve Variable Displacement Efficiency

The TurnValve saves you money from the start. Coupled with the AutoSentry ES+, the Electra-Saver yields unparalleled efficiency and flexibility.

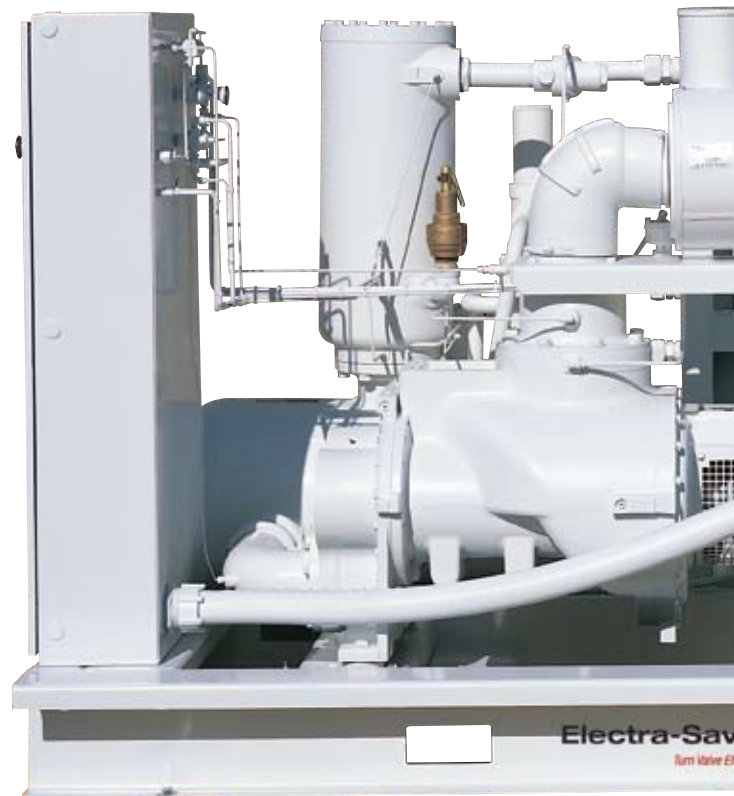

### Optional Enclosure

Why pay for an enclosure you don't need? Many installations are better off without one. When one is of benefit, Gardner Denver can supply a standard enclosure or a low sound design for more stringent noise requirements.

### Heavy Duty, Two-Stage Inlet Filter

Dirt and dust that enter the compressor can adversely impact lubricant and machine life. A 5-micron inlet filter with an efficiency rating of 99% is standard equipment on the Electra-Saver. It is a separate option on many other compressor packages.



### The Best Motor in the Business

The **Electra-Saver** motor is the most durable motor available. These cast iron, EPAAct efficient motors contain more winding material than any other motor. The best motor with the best compressor makes for the best drive train you can find.

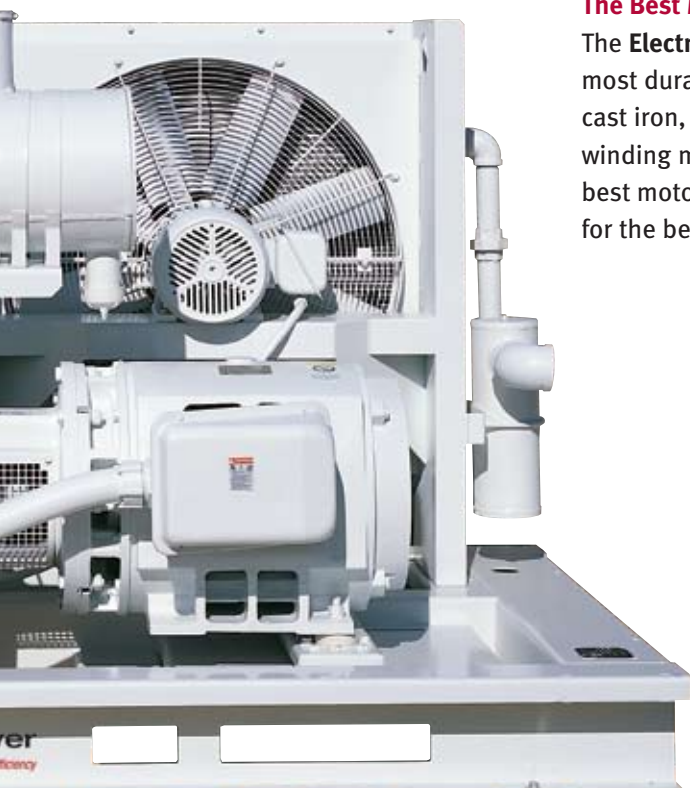

*Warranty*

**GD**  
GARDNER DENVER

A robust standard warranty accompanies each Gardner Denver compressor package. The Electra-Saver has a standard 5-year warranty on motors and a 2-year warranty on the air end, coolers and AutoSentry ES+ controller. This is Gardner Denver's way of putting our money where our mouth is—dependable high quality air compressors.

### Serviceability Supreme

Maintenance personnel love the Gardner Denver Electra-Saver. Components are not crammed into the smallest possible footprint. All filters are easily accessible and no piping needs to be disconnected to service the separator.

## Let Gardner Denver Take Control Of Your System

To ensure total system reliability, Gardner Denver provides a broad range of dryers, filters, oil/water separators, drains, cleaning fluids, and aftercoolers. ONE-STOP shopping from Gardner Denver assures that all components of the system are designed to work together and are backed by customer support today and for years to come.



### FIL Series High Efficiency Filters

A full range of filters 20–21,250 cfm; coalescing, particulate, and activated carbon for the removal of water, oil, and particulates from compressed air.



### DS2 Series Evacuator Drain Valves

A full family of zero air loss, energy efficient demand drains. Ruggedly designed to effectively and reliably prevent moisture damage to dryers, air tools, gauges, and other critical components.



### RNC Series Refrigerated Dryers

A full line of high quality refrigerated dryers with features and benefits unmatched by the competition. Designed to produce dew points as low as 38°F in compressed air.



### DGH Series Desiccant Dryers

A complete line of desiccant dryers for the removal of water vapor in compressed air to dew points as low as -100°F.

# Gardner Denver®



Member



[www.GardnerDenverProducts.com](http://www.GardnerDenverProducts.com) [maggie@gardnerdenver.com](mailto:maggie@gardnerdenver.com)

Gardner Denver, Inc. 1800 Gardner Expressway, Quincy, IL 62305

Customer Service Department

Telephone: (800) 682-9868 FAX: (217) 224-7814

©2009 Gardner Denver, Inc. Litho in U.S.A. GS-SAV-FAM 2nd Ed. 4/09